

Barrier for protecting structures, buildings and storage areas from floods or storm water. The barrier is autonomous and requires no external energy sources to function. Activates automatically without any intervention or control input. The barrier is freely passable when inactive.

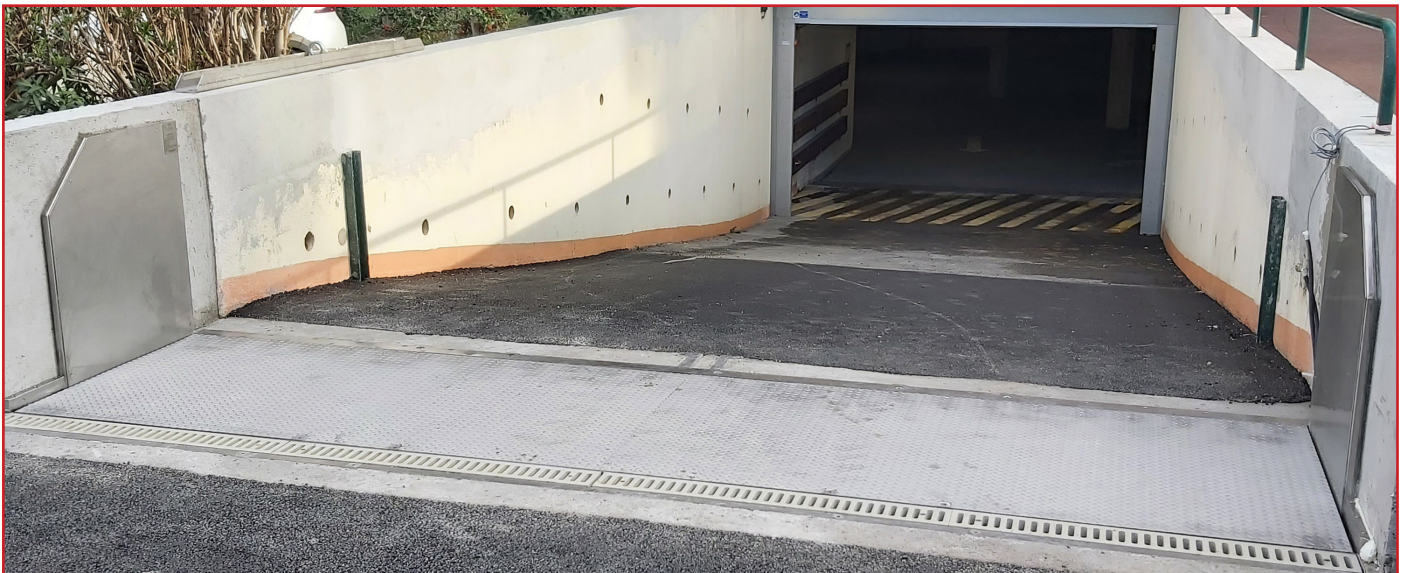

022022.0193EN

Other flood protection solutions on offer:



MOBILE BARRIER:
INOVA AL



MOBILE BARRIER:
FLOM



PASSIVE
DAM



WATERTIGHT DOOR:
PPD



WATERTIGHT
GATE



ANTI-CONTAMINATION
BARRIER



MOBILE BARRIER:
JPZ



ATYPICAL
WATERTIGHT SOLUTIONS



PASSIVE DAM

FLOOD PROTECTION



Automatic protection 24/7 without external power source.

It will automatically return to the rest position when the water recedes.

All components are made of anti-corrosion materials.

Dimensions always tailored to each project.

Load capacity of up to 12 000 kg.

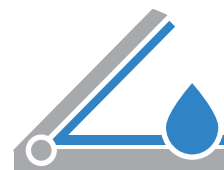

PRODUCT DESCRIPTION

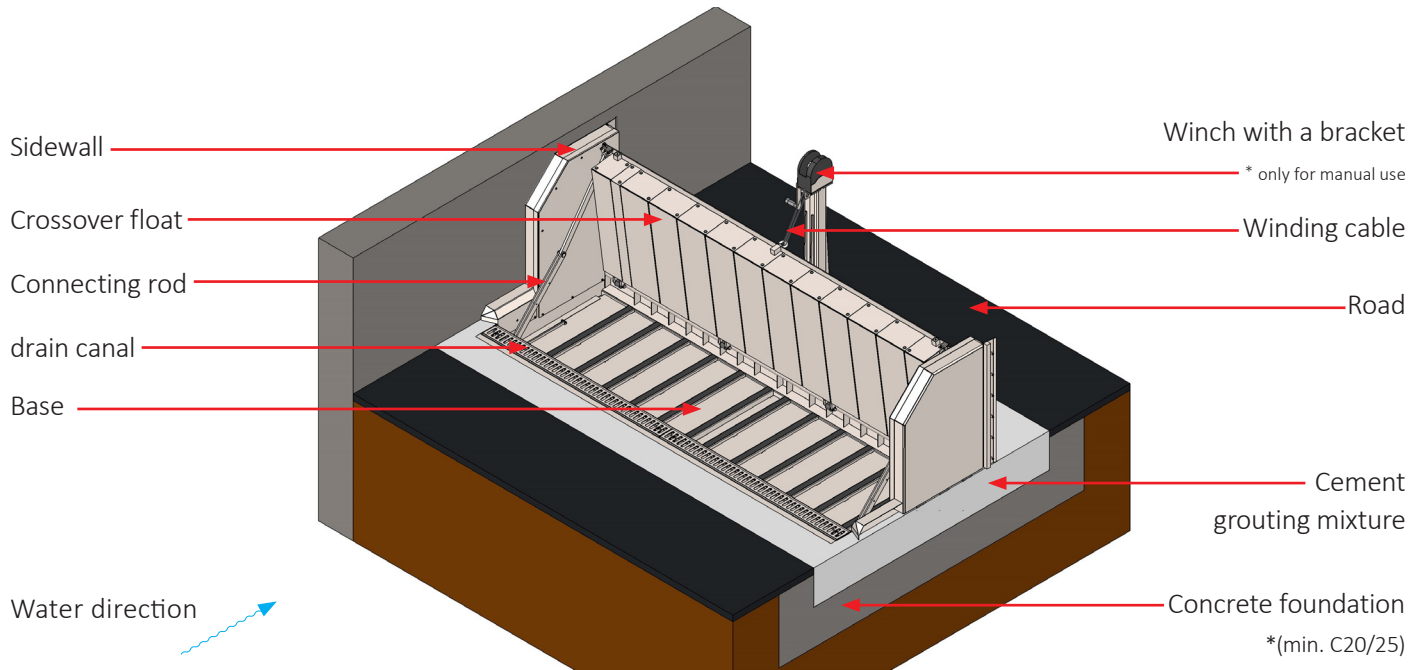

BARRIER FUNCTION

The barrier operates automatically using the principle of buoyancy. If the capacity of the drainage system reaches its maximum, the barrier automatically activates and holds back the excess water. The barrier is activated continuously based on the flow rate of the incoming water and thus fulfils its function at all times. After the water gradually recedes, it descends with the water column and finally closes itself. It can also be opened manually with a winch (e.g. for maintenance)

The barrier in passive position, allowing free passage.

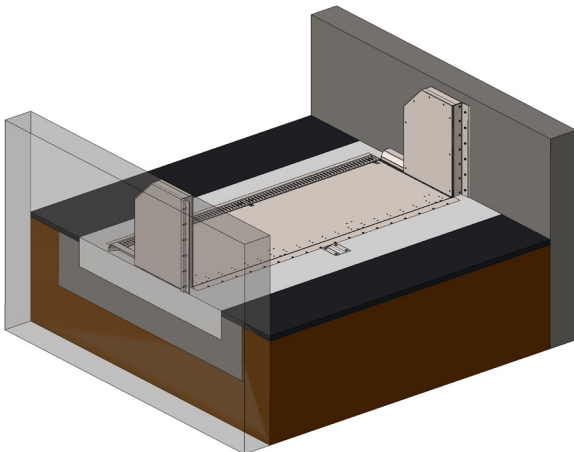

The barrier in active position, holding back water.

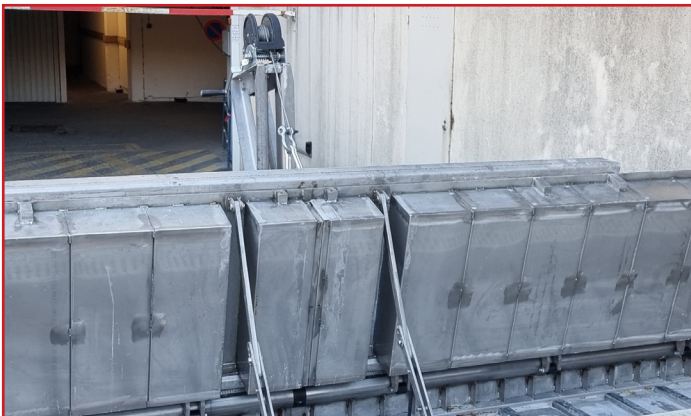
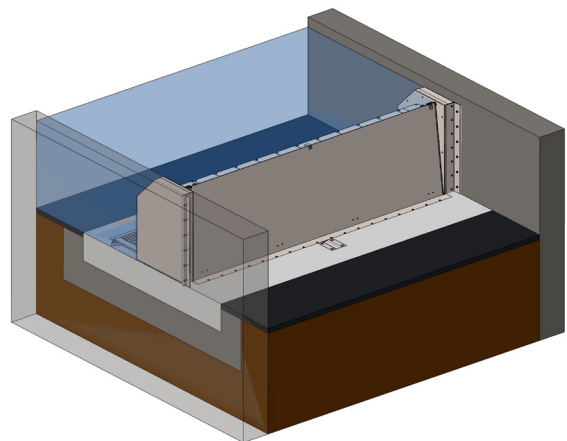

Manually raised barrier with winch.



A barrier in active position.



COMPONENTS OF THE BARRIER

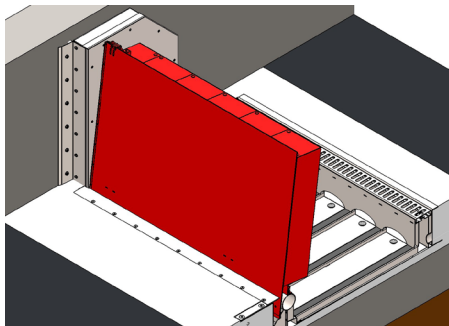

Crossover float

The moving part of the system that reacts to the water level thanks to buoyancy.

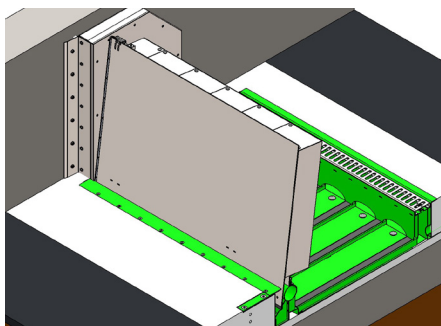

Base

The fixed part of the barrier to which the mobile crossover float and adjustable sidewalls are mounted. The base pan includes a drainage channel with a crossover grate.

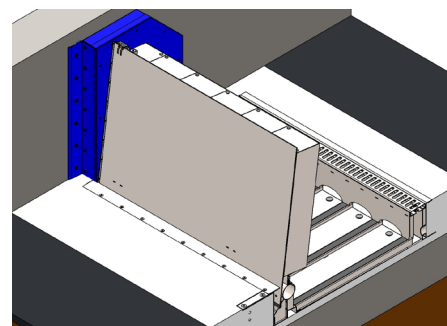

Sidewall

Serves as a sealing surface for the crossover float.

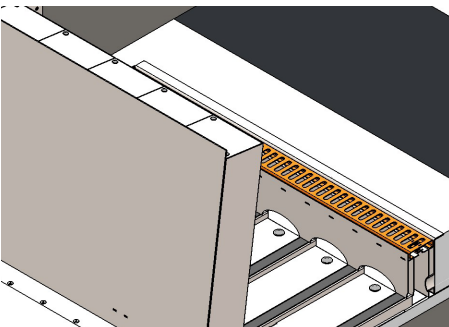

Crossover Grate

Used for draining water from the road.

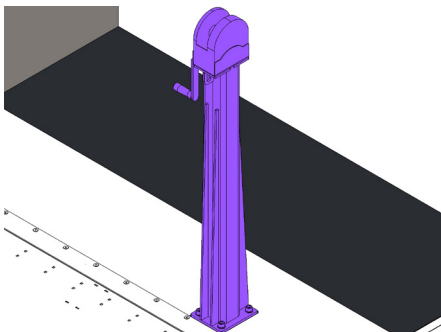

Winch with a bracket

Allows you to raise the crossover float manually. It is used for easy and safe maintenance, during service and to help with assembly.

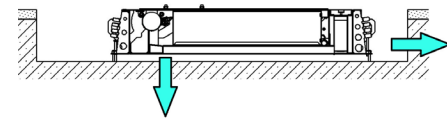

Drain pipe

It is used to connect to the drain canal - either under the barrier or in front of the barrier.

TECHNICAL SPECIFICATION

Load capacity:	12 000 kg
Maximum width of the opening:	Maximum segment length 3,000 mm; segments can be interconnected
Maximum water column:	2 000 mm
Minimal water column:	500 mm
Maximum slope for placing the barrier:	35%
Operating temperature range:	0°C/ +50°C (platí pro aktivní pozici)
Material of the main parts of the barrier:	AISI 316L (1.4404)
Sealing:	EPDM
Drain:	Connected to sewerage
Optional accessories:	Light signalization

